

**Blindplatte NG25
Lochbild DIN 24340
ISO 4401**

**incl. O-Ring
4x 29x2,5
3x 12x2**

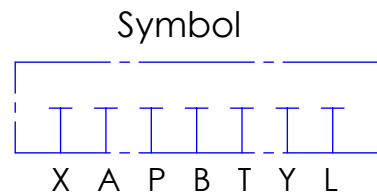
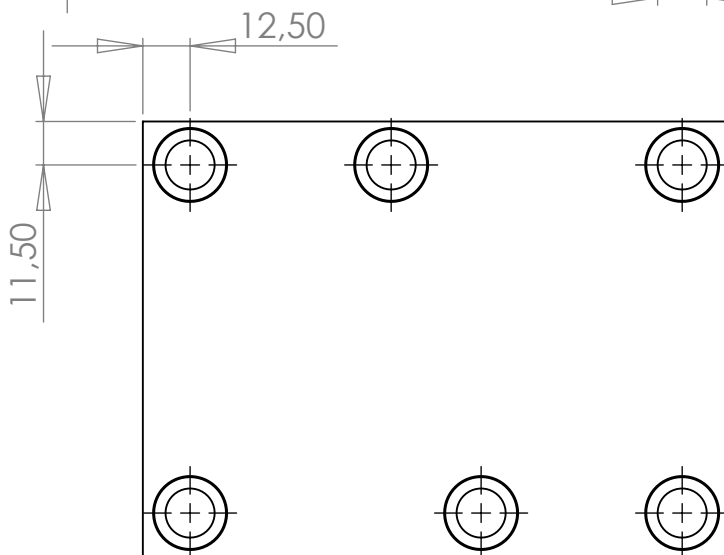
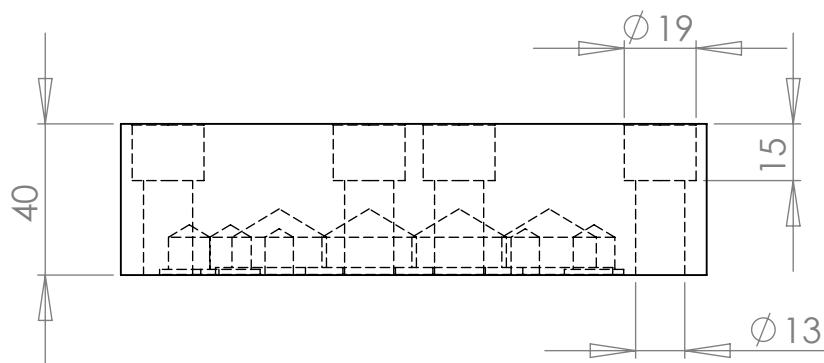

Bestell Nr.: 12500001

Sonderausführungen auf Anfrage

Änderungen vorbehalten

MAX. 315 bar

H & S

Hydraulik & Steuerblöcke

Hartmannstr. 55
72458 Albstadt
Tel.: 07431/701794
Fax.: 07431/701793

MATERIAL		AICuMg1 F38
NEXT ASSY	USED ON	FINISH
APPLICATION		DO NOT SCALE DRAWING

NAME	DATE
DRAWN R. Grotz	05.12.07
CHECKED	
ENG APPR.	
MFG APPR.	
Q.A.	
COMMENTS:	
150x115x40	

H & S

Blindplatte NG25

SIZE	DWG. NO.	REV.
A	12500001	A
SCALE:1:5	WEIGHT:	SHEET 1 OF 1